

2025 Southwest Dental Conference

Exhibitor Rules & Regulations

1. Management

The exhibition of the Southwest Dental Conference is conducted under the direction of the Dallas County Dental Society (the "Association") and its agents or employees acting on its behalf.

2. Character of Exhibits

The Association reserves the right to decline or prohibit any exhibit that, in its judgment, is not suitable to or in keeping with the character of the exhibition. This reservation is all-inclusive and concerns persons, things, conduct, printed matter and souvenirs.

3. Rules Governing Exhibitors

The Association shall have the right, which is hereby expressly reserved, to interpret or amend the rules and regulations, and its decision is final. Exhibitors, by applying for and accepting exhibit space, agree to abide by any rules or regulations that may hereafter be adopted, which shall be as much a part of the rules and regulations as though originally included. Exhibitors also agree to abide by the rules and guidelines of the Hilton Anatole Dallas and any other vendors contracted to provide services for the Southwest Dental Conference. All issues not specifically addressed are subject to the decision of the Association. All exhibitor requests for permission to vary from any of these rules and regulations must be sent to the Association before November 15, 2024.

The Association reserves the right to cancel this contract in case exhibitor displays or promotes any product which is not authorized by the Association; or if the premises should be damaged so as to render the premises untenable or unfit for use.

In such event, all payments previously made on this contract shall be prorated, and the prorated portion thereof shall be returned to the exhibitor by the Association and the Association shall be released from any and all claims for damages, loss, costs or expenses sustained or incurred by the exhibitor by reason of such cancellation. The exhibitor, its employees, agents or representatives shall observe and comply with all federal, state and municipal laws, rules and regulations in the use of such exhibit space. On all matters not herein covered, or on any possible differences, final decision is subject to the judgment of the Dallas County Dental Society.

4. Enforcement of Rules and Regulations

Breach of any rule or regulation by any exhibitor will subject exhibitor to restriction, termination or sanctions, including loss of priority status and/or future exhibition privileges. The rules and regulations presented in this prospectus are intended to bring order and fairness to the exhibition.

5. Application for Exhibit Space

The Association reserves the right to refuse space to any exhibitor, exhibit or any part thereof, which in its judgment is not acceptable. The Association reserves the right to refuse the application of any exhibitor whose business operations conflict in any manner with any of the policies of the Dallas County Dental Society. The decision of the Association shall be final and the exhibitor agrees to abide by, and not contest in any manner, that decision.

6. Payment/Refund Information

All fees for exhibit space must be paid by March 1, 2025 or the space will be cancelled immediately and resold without notification. A 50% deposit for each booth must accompany the application. Contracts received after March 1, 2025 must be accompanied by payment in full. Fees are payable to Southwest Dental Conference in U.S. funds by check, money order, MasterCard, Visa or American Express. Refunds requested prior to March 15, 2025 will be subject to a 25% administrative fee. Requests for refunds must be received in writing. No refunds will be made after March 15, 2025.

7. Booth Assignment

Assignment of exhibit space shall be made solely at the discre-

tion of the Association, with consideration given to requested booth space(s). The Exhibit Hall floor plan can be viewed online at www.swdentalconf.org. The floor plan is subject to change and should not be considered contractual. Applications receive priority assignment status based on when the contract is received, the number of years exhibited and number of booth spaces contracted at the Southwest Dental Conference. The Association cannot guarantee the separation of competitors, but will make every effort to do so. The Association reserves the right to relocate exhibitors if it becomes necessary because of circumstances beyond its control, or if it is in the best judgment of the Association. Applicants are advised that final confirmation of exhibit space may be slightly delayed due to the volume of applications received at the time of submission, and deposit of the applicant's check or processing of credit card payment should not be construed as final confirmation of acceptance. Until the applicant receives final written acceptance or denial of exhibit space, any funds expended for the development or construction of an exhibit booth are done so at the applicant's own risk.

8. Exhibit Space

Booths are 10-foot deep by 10-foot wide and include drape for back and side walls; one two-line identification sign with company name and booth number; and one undraped 6-foot long by 30-inch high table, provided it is ordered via the special order form in the Exhibitor Service Kit. See specifications for booths and hanging signs herein. Nothing may be attached directly to the draping. The Association will provide carpet for aisles and other public areas. **Exhibitors are required to provide carpet for their booth(s), ordered via the Exhibitor Service Kit.**

Drapes must be certified as flame retardant by the fire marshal. Electrical outlet(s) may be ordered via the order form in the Exhibitor Service Kit. All displays must be confined within booth space. All aisles must be kept free and clear, and are subject to the control of the Association. All displays must be approved by the Association. Nailing or attaching to any part of the building is prohibited. No combustible materials will be permitted in the Exhibit Hall. Helium balloons are prohibited.

Equipment in operation must provide adequate protection against dripping of any liquid on the floor. All empty crates and packing materials must be removed from the booth for proper storage, and there will be no storing of cartons, packing materials, etc. within the booth. The aisles are the property of the entire exhibition, and each exhibitor has the responsibility to assure proper flow of traffic through the entire show.

Aisles must not be obstructed at any time. When large crowds gather for sampling, to watch a demonstration or for a contest and interfere with the flow of traffic or create excessive crowds in neighboring booths, it is an infringement on the rights of other exhibitors.

9. Forfeiture of Space

Exhibitors who 1) resell or sublet exhibit space under any circumstances (two or more firms cannot occupy the same booth space) without express approval of the Association; 2) render their badges to unauthorized persons; 3) do not set up their booth(s) in the Exhibit Hall by opening time of the first day or 4) begin tearing down their booth before the show officially ends will forfeit their exhibit space and/or future priority assignment status and/or future exhibition privileges.

10. Show Decorator

All requests for additional services should be addressed to the official show decorator listed in the Exhibitor Service Kit. The Exhibitor Service Kit will be online approximately two months prior to the Conference with the necessary order forms. Table covers, drapes, furniture and accessories may be ordered from the official show decorator, along with any additional work or equipment that might be required. Carpet, audio-visual services, freight, floral, portable booth rental, computer rental, etc. will be available at special show rates.

11. Shipping Instructions

Forward all materials to the official show decorator with Southwest Dental Conference and booth number(s) indicated on the address label. Include full instructions for delivery to the Hilton Anatole Dallas; bill of lading; number of crates or cartons; firm name and address; and representative in charge. All shipments must conform to normal shipping instructions and must be sent prepaid. Shipments received within 30 days of show set-up date will be stored by the official show decorator without charge. Shipments are delivered to the Hilton Anatole Dallas per your instructions, empty crates removed, stored and re-delivered. The Hilton Anatole Dallas does not have facilities to receive or store freight prior to set-up day. Your transfer company will prepare the bill of lading per your shipping instructions and ship.

12. Exhibitor Appointed Contractor

If utilizing a contractor other than the official show decorator, written notice must be submitted to the Association 45 days prior to the Conference. Such contractor must provide certificate of liability insurance to the Association 30 days in advance of the Conference. Your contractor will not be allowed in the Exhibit Hall if a certificate of insurance is not received.

13. Exhibitor's Official Representatives

Each exhibitor should submit, via the exhibitor badge request form available online, names of all official representatives attending the meeting. Exhibitors are allowed six (6) free badges per contracted booth space for the entire show. Should the number of badges exceed this number, a \$15.00 charge per person will be assessed and billed to the exhibiting company. Exhibitors registering onsite must provide credentials (i.e., business card or authorization on company letterhead). Exhibitor representatives are required to staff their exhibit booth during all official exhibition hours.

14. Show Hours

Exhibitors must set up during the approved time frame designated by the Association. Early set-up times will be handled on a case-by-case basis. **Early tear-down is not permitted and will result in loss of priority points status.** Set-up for exhibitors will be Thursday, August 21, 8:00 a.m. – 8:00 p.m. Show dates and times are Friday, August 22 from 9:00 a.m. – 6:00 p.m. and Saturday, August 23, from 9:00 a.m. – 1:30 p.m. **Move out begins at 1:30 p.m. on Saturday, August 23 and ends at 7:30 p.m.**

15. Security

Perimeter guards will be provided from set-up through tear-down, but the Association is not responsible for any loss or damage to exhibitors' goods or property. Additional or individual security personnel must be provided by the Association.

16. Selling in Aisles

All business activities of the exhibitor must be confined to the booth space rented. No business activities are to be conducted in any aisles, lobbies, other booths, or other areas of the Exhibit Hall or Hilton Anatole Hotel. Exhibitors may not stop attendees in the aisle. Violators will be subject to forfeiture of booth space.

17. Solicitation by Non-Exhibitors

Firms and representatives not assigned exhibit space by the Association are prohibited from soliciting business in any form in the Exhibit Hall. Violators will be required to leave the Exhibit Hall.

18. Sales on Show Floor

Direct exhibit floor sales are allowed during regular Exhibit Hall hours. However, purchased products cannot be delivered to the Hilton Anatole Hotel. **Exhibitors are responsible for any and all tax permits required by Texas law or local ordinance.**

19. Food and Beverage

Exhibitors must comply with the Hilton Anatole Dallas regulations regarding food and beverage dispensing. A temporary health permit is required for food sampling (such as drinks mixed and distributed from a booth). Handing out candy,

cookies or popcorn does not qualify as food sampling provided those items are purchased from the official food vendor of the Hilton Anatole Dallas. All food and beverages must be ordered through and serviced by Hilton Anatole. No outside food and beverages are permitted. Contact the Exhibits Manager for more information.

20. Theater Presentations

Exhibitors whose booth(s) involves a theater or ongoing presentation must submit a complete lineup of the presentations and scheduled speakers by June 1, 2025.

21. Laser Exhibiting

Exhibitors showing lasers must comply with recommended safety precautions for the demonstration of lasers; therefore, the following procedures apply:

- Lasers must be operated only within a suitable enclosed space with eye protection for those viewing and operating the laser.
- All demonstrations of CO2 lasers must be conducted in clear plastic boxes with top and sides enclosed.
- Appropriately colored plastic cubicles must also be available for other types of lasers being demonstrated, especially dye and argon lasers.
- No laser equipment may be left unattended in operable condition.
- There shall be no promotion, demonstration or suggestion with respect to dental auxiliary use of these instruments.
- A description of each piece of laser equipment and their safety features must be submitted to the Association by June 1, 2025. Failure to submit this description can result in the denial of the lasers to be shown/demonstrated or the denial of exhibit space.

22. Exhibitor Sponsored Contests

Exhibitors must obtain written permission from the Association to sponsor any type of contest, raffle or drawing for prizes. The following rules must be adhered to:

- The exhibitor must comply with all local, state and federal laws that apply to such raffles, contests or drawings.
- Contest, raffle or drawing rules must be posted at the booth. The rules must include: eligibility, date and time of drawing (contest, raffle); the words "no purchase necessary to enter;" odds of winning; how winners will be notified; and how participants can find out who won, etc.
- The Association must be notified of the name(s) of the winner(s) when the prize(s) have been awarded.

23. Sound/Music

Speakers and other sound devices should be positioned so as to direct sound into the booth and not toward the aisle or neighboring booths. To prevent disturbance to other exhibitors, sound levels should not exceed 85 decibels. Music played in booths is subject to copyright laws. Exhibiting companies are responsible for paying copyright fees for music played in their booths. ASCAP, BMI and SESAC are authorized organizations that collect copyright fees.

24. Photography/Video Recording

Exhibitors are not allowed to photograph or videotape any booth other than that of the company they represent. Photography and videotaping of a company's own booth is permitted only with the prior approval of the Association before or after Exhibit Hall hours. Security escorts for such activities must be arranged through the Association and the cost of same may be charged to the exhibitor.

25. Liability and Indemnification

Each exhibitor signing an application expressly releases and discharges the Dallas County Dental Society, the Southwest Dental Conference, the Hilton Anatole Dallas and their respective employees, agents, representatives, assigns, contractors and subcontractors from any and all liability, workers compensation claims and liability, damages, actions, losses, claims and expenses (including attorney's fees and court costs) of every kind and character arising in any manner out of this contract or its performance. Each exhibitor further expressly agrees to indemnify and hold harmless the Dallas County Dental Society and the Southwest Dental Conference, its employees, agents, representatives, assigns, contractors and subcontractors from any liability, claim and damages of every kind and character arising out of the actions or omissions of the exhibitor or the exhibitor's employees, agents or representatives.

26. Insurance

Exhibitor must provide a certificate of liability insurance showing the policy in effect through August 23, 2025 and evidence of insurance coverage with minimum limits of \$1,000,000 combined single limit bodily injury and broad form property damage coverage, including broad form contract liability. In addition to the exhibitor, the certificate of insurance must name the Dallas County Dental Society as additional insured. **Exhibitor will not be allowed to setup without proof of insurance.**

Booth Descriptions

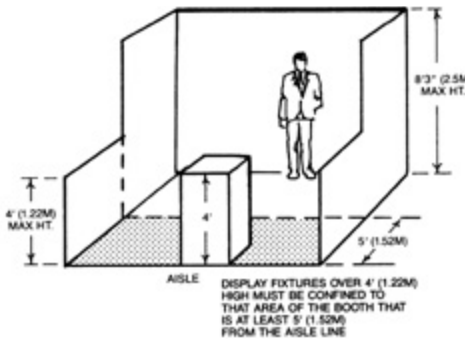

In-line Booths: Booths consist of 8-foot-high back drape and 4-foot-high side drape mounted on aluminum tubular frames. There is a 12-foot height limitation on in-line booths. Back of booth extending above the drape must be finished with no copy of any kind on it. Solid construction in excess of 4 feet in height must be a minimum of 5 feet back from the aisle to allow sight lines to adjacent booths.

End Cap Booths: When assigned a 10-foot by 20-foot end cap space (two corner booths at the end of an aisle), please remember that the exhibit back wall must conform to exhibit rules. The centered back wall measures 10 feet across and is 8 feet high. The remainder of the back wall will not

exceed 4 feet in height. Booth may extend to 12 feet in height along the 10-foot wide section of back wall. Back of booth extending above the drape must be finished with no copy of any kind on it. **Five feet on each side must be maintained at the 4-foot height level to allow sight lines to adjacent booths.**

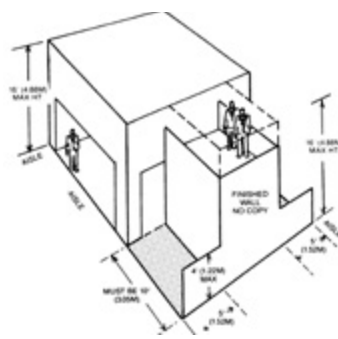
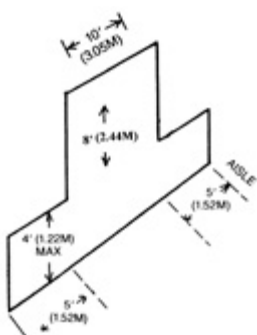

Peninsula Booths: A peninsula exhibit is a grouping of 10-foot by 10-foot booths with aisles on three sides. The back wall of a peninsula booth must be on the non-aisle side and not exceed 16 feet in height. The centered back wall measures 10 feet across and is 8 feet high. The remainder of the back wall will not exceed 4 feet in height. All portions of this back wall must be finished with no copy of any kind. Peninsula exhibits must be designed to be accessible from all three aisles.

Island Booths: An island exhibit is an open area of exhibit space with aisles on all four sides. Free form exhibits may extend to all outer edges of the booth space, but the design of the booth must allow for see-through visibility and accessibility from all four sides. An exhibitor who wants to

create an island booth smaller than those shown on the floor plan must purchase, in addition to the number of booths desired in the island, the two booths that connect the proposed island to the remainder of the booths in the block to create an aisle on the

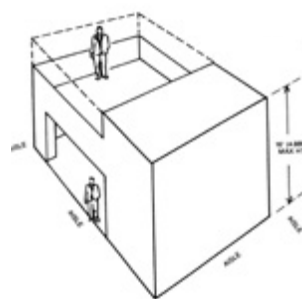

fourth side of the block of booths. Approval by the Association is required if any exhibitor with an island space wants to go above 16 feet; plans to have a solid wall higher than 4 feet the length or width of the space; or plans booth construction with an unusual or nonstandard configuration. Important: when installing a display with a ceiling or second level you must check with the local fire department to ensure that the display meets the necessary fire and safety regulations involving smoke alarms, fire extinguishers, sprinkler systems, etc.

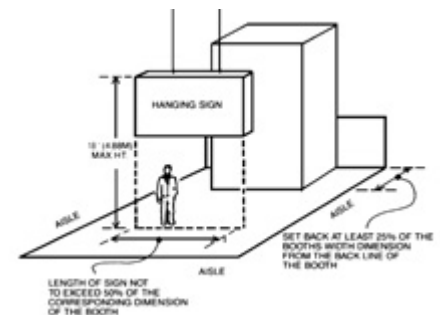

Hanging Signs: There are limited points in the exhibit hall from which to hang signs, banners, etc. Exhibit booth signs, banners, booth ceilings, canopies, lighting grids or other exhibit-related equipment should be free-standing and floor supported where possible. Requests for approval of hanging signs and banners must be submitted to the Association by July 1, 2025. Rigging of hanging signage is the exclusive responsibility of Encore, the required exclusive rigging provider for the Hilton Anatole. Group must engage Encore for all event rigging needs. Rigging equipment, all truss (including ground supported truss), chain motors, span sets, shackles, steel, deck chain, etc. must be provided exclusively by Encore. Current rigging policies and procedures are found on the Encore website: <https://encoreglobal.com/locations/hilton/tx/hilton-anatole/>.